

# ACB2000 SERIES ELECTRIC ACTUATOR

PRODUCT  
TECHNICAL  
INFORMATION

PTI 2020  
FEBRUARY 2001  
MPC

## INTRODUCTION

The ACB2000 actuator is a rotary output, linear torque proportional electric servo designed for mechanical actuation of fuel system control levers requiring torques in the 5 lb-ft range. The actuator is energized by appropriate speed control unit signals, and is capable of 35 degrees of rotation with torques as high as 12 Lb-Ft.

Internal springs provide fail safe operation by forcing the actuator to the fuel shut off position when the actuator is deenergized. Both CW and CCW shafts are available. Engine applications include large block pumps, and dual medium and some large size carburetors.

Its matching speed control, the ESB 5300, offers a versatile range of features such as cranking termination, overspeed sensing, fuel limiting during start up, and speed ramping to minimize exhaust emissions during the starting cycle.

## DESCRIPTION

The ACB2000 actuator is an electromagnetic servo device which can be integrated into a closed loop control system. A typical engine control system can be described as follows. An electrical signal, proportional to engine speed, is generated by a magnetic speed sensor. This signal is sent into the electronic speed control unit which compares it to the preset engine speed setting. If the magnetic speed sensor signal and the engine speed setting are not equal, a change in current from the speed control unit to the actuator will alter the magnetic force in the actuator.

The change in magnetic force causes the actuator shaft to rotate. The rotation of the actuator shaft will then adjust the fuel to the engine and cause the engine speed to be equal to the desired speed setting. Shaft rotation is proportional to the amount of current and counter balanced by the internal springs.

Since the design has no sliding parts, and is totally sealed, its reliability is outstanding. No maintenance is necessary.

## SPECIFICATIONS

### PERFORMANCE

Available Torque (See Figure 1) . . . Max. 12 Lb-Ft (16.3 Nm)  
Maximum angular travel of shaft . . . . .  $35^\circ \pm 1^\circ$  CW/CCW

### POWER INPUT

Operating Voltage . . . . . Nominal 24 Volts  
Normal Operating Current . . . . . Up to 5 Amps  
Maximum Stall Current (Short Duration) . . . Up to 12 Amps

### ENVIRONMENTAL

Temperature Range . . . . .  $-65^\circ$  to  $200^\circ\text{F}$  ( $-55^\circ$  to  $+95^\circ\text{C}$ )  
Relative Humidity . . . . . Up to 100%  
All Surfaces Finished . . . . . Fungus and corrosion resistant

### PHYSICAL

Dimensions . . . . . See Figure 4  
Weight . . . . . 30 lbs (13.6 kgs.)

### RELIABILITY

Vibration/Shock . . . . . up to 20g @ 50-500 Hz  
Testing . . . . . 100% Tested

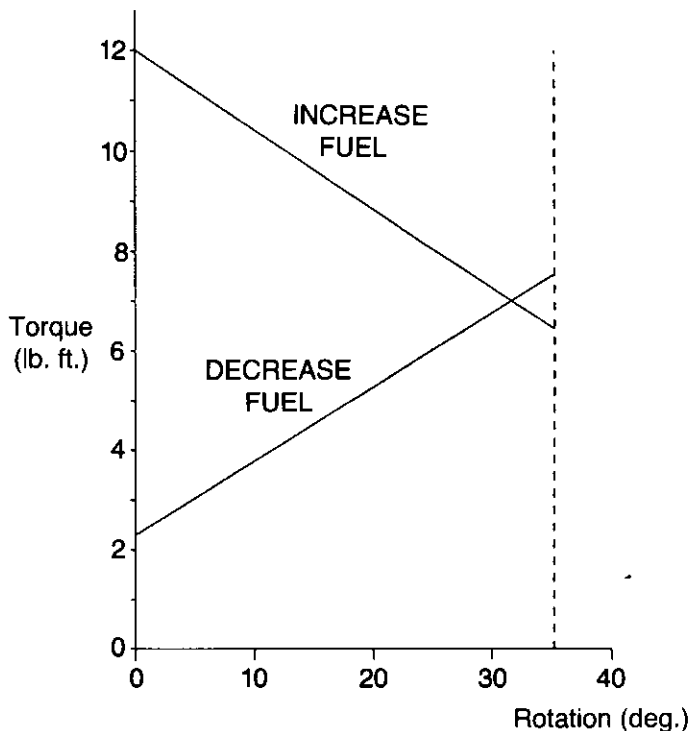

Figure 1 Actuator Torque

## INSTALLATION

The actuator must be rigidly mounted as close as possible to the engine throttle lever. The shaft on either end may be used. When selecting the mounting location, consideration must be given to possible linkage obstructions. Normal engine vibrations will not affect the actuator operation because it is dynamically balanced. The preferred mounting configuration is with the actuator feet down, as shown in Figures 3 and 4.

The linkage must be direct, short, and as light as possible. High quality, low friction ball bearing rod ends should be used throughout the linkage system.

The linkage should be adjusted so that the fuel control minimum and maximum fuel stops are used rather than the internal actuator stops.

A. Drill the actuator mounting holes in a prefabricated mounting bracket. The mounting hole configuration is illustrated in Figure 4. The position of the actuator on the mounting bracket must insure minimal misalignment between each end of the governor system linkage. The linkage ball bearing rod ends can tolerate a maximum misalignment of 10°.

B. Attach the actuator bracket to the selected location on the engine.

C. Attach the actuator securely to the bracket using 5/16-18 or M8 hardware.

D. Adjust and secure the linkage rod and ball bearing rod ends to the actuator lever and fuel control levers.

### Linkage Systems

For proportional actuators to operate with linear control systems, it is important to obtain a linear relationship between actuator stroke and fuel delivery.

### Diesel Fuel Systems

For diesel fuel systems, the linkage configuration is typically linear. Cummins PT fuel pump systems are an exception and should be set up like carbureted applications. The actuator lever should be nearly parallel to the fuel control lever and perpendicular to the linkage rod at the mid-fuel position. See Figure 2.

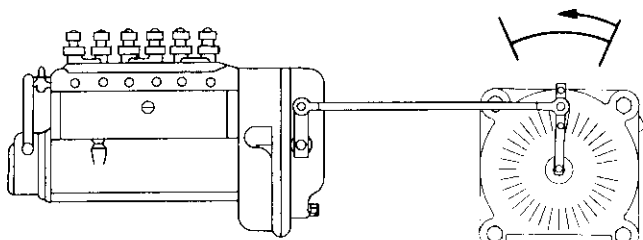
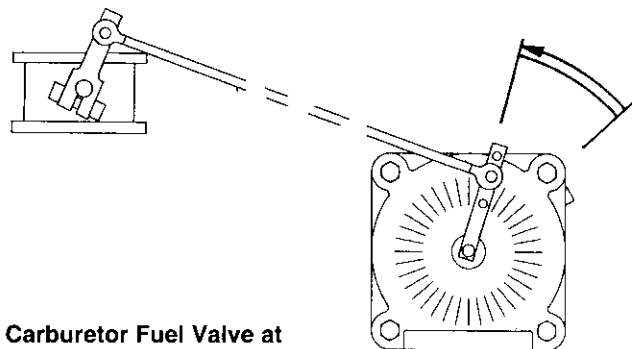

Figure 2 Fuel Control Lever at Mid Fuel Position

### Carbureted Fuel Systems

For carbureted fuel systems, the linkage is typically nonlinear. The carburetor butterfly valve lever should be parallel with the actuator lever and the linkage rod should be perpendicular to the actuator lever at the maximum fuel position. See Figure 3.



Carburetor Fuel Valve at Full Fuel Position  
Figure 3

E. Fabricate a two conductor wiring harness to connect the actuator to the speed control unit. The actuator operates on 24V. For short cables, less than 9 feet (3m), the recommended wire size of the cable harness is at least #16 gauge (1.5mm<sup>2</sup>). The wiring must be capable of handling maximum current levels of 12 amps and typical current levels of 6 amps without experiencing a significant voltage drop. Larger gauge wire will be necessary for cable lengths greater than 9 feet (3 m).

F. Connect the cable harness to the ESD5300 speed control unit referring to publication PTI 1040.

### Before Starting the Engine

Recheck the linkage to insure that both the linkage and levers are securely fastened. Push the actuator lever to the maximum fuel position and reconfirm that the linkage is not binding and that friction is minimal. Upon release, the linkage must return quickly and smoothly to the minimum fuel position.

## LINKAGE ADJUSTMENT

The linkage can be optimized by adjusting it so that the actuator current difference from no engine load to full engine load is approximately 3.5 amps.

The no load current is altered by varying the length of the linkage, and the range is adjusted by changing the actuator lever hole to which the ball bearing rod end is attached.

On diesel applications, smaller angles of actuator travel may improve transient performance, but will reduce the force available at the fuel control lever. Adjusting the actuator to operate through at least one half (18°) of its stroke will provide near optimum response.

With carbureted systems, the full travel is normally used.

# TROUBLESHOOTING

If the governor system fails to operate, make the following electrical and mechanical tests.

Measure the resistance between the two actuator terminals. The resistance should be  $2.0 \pm 0.1$  ohms.

Measure the resistance between one actuator terminal and the actuator housing. The resistance should be greater than 1 Meg ohm.

Refer to the ES 5330 publication, PTI 1041, for instructions on how to fully energize the actuator. Disconnect any linkage attached to the actuator lever and fully energize the actuator. Manually move the actuator through its full range of travel and feel for any binding or friction.

If no binding is present, refer to the ESD 5330 publication for further troubleshooting procedures.

Figure 4 Outline

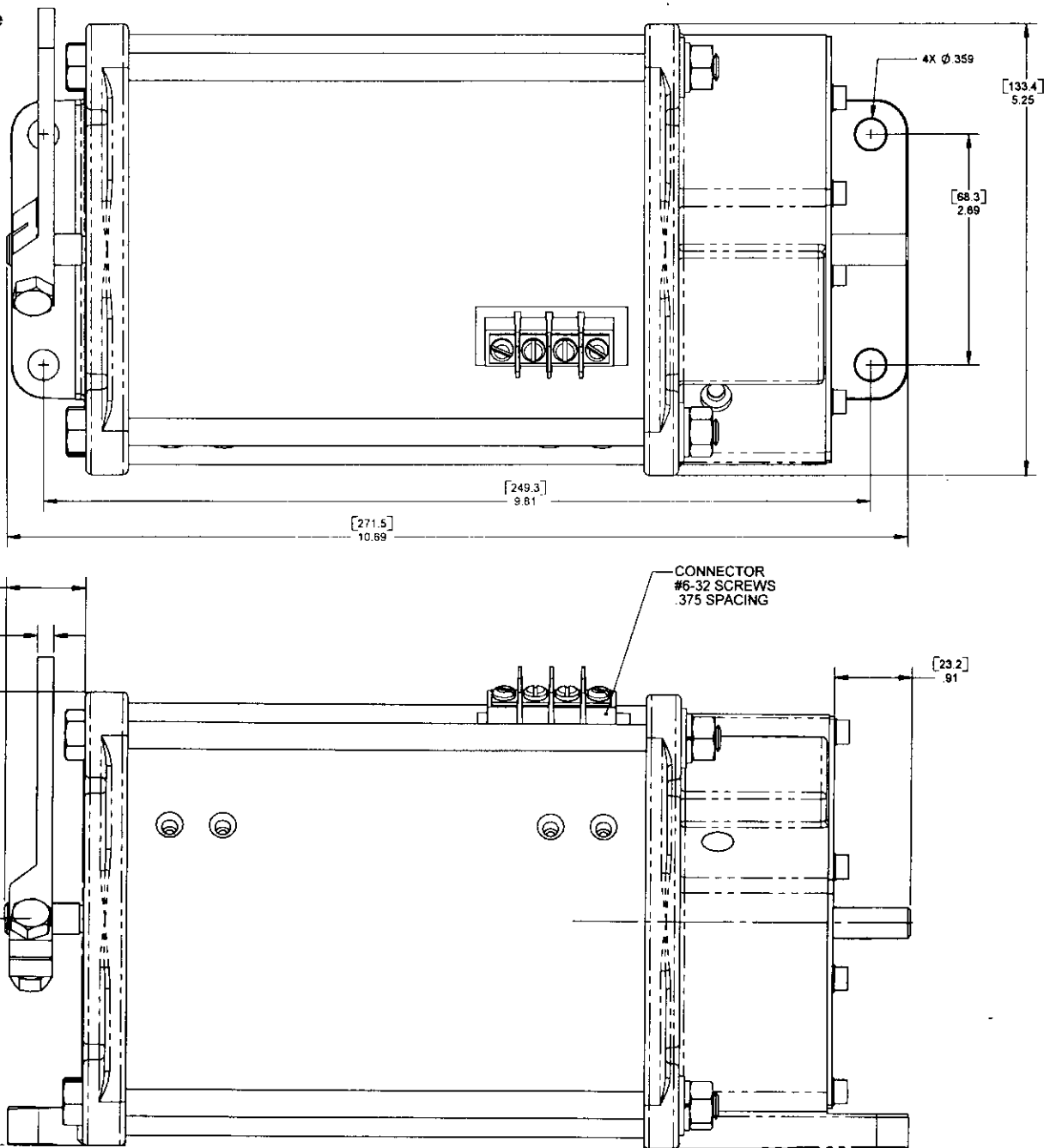

720 Silver St. • Agawam, MA 01001-2907, USA • (413) 786-5600

FAX (413) 786-5666

e-mail: [info@governors-america.com](mailto:info@governors-america.com)

Internet: [www.governors-america.com](http://www.governors-america.com)